

TYPICAL DRIVEWAY APPROACH DETAIL

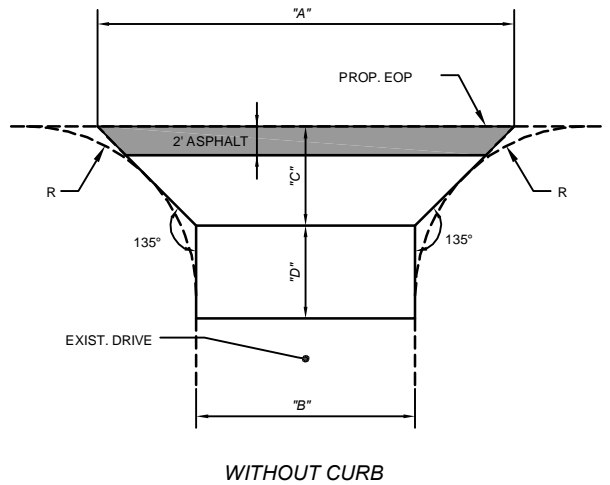

CONCRETE DRIVEWAY DETAIL

(ITEM SPECIAL - CONCRETE DRIVEWAY) *

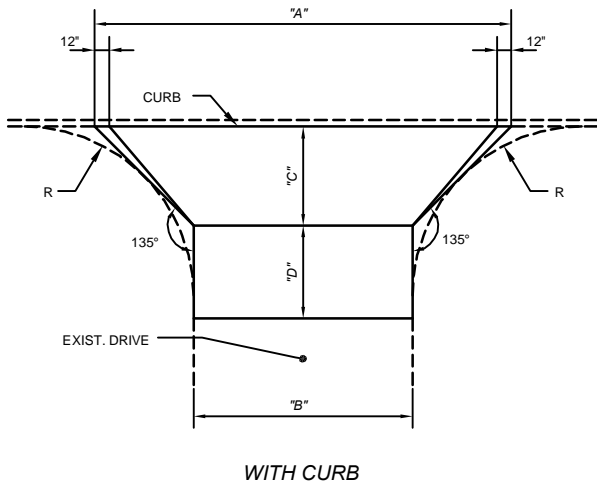
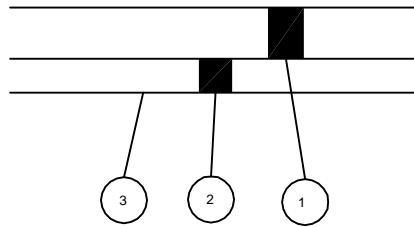

LEGEND

- 1 ITEM 452 6" FIBER-REINFORCED PORTLAND CEMENT CONCRETE, CLASS MS
- 2 ITEM 304 4" AGGREGATE BASE
- 3 ITEM 204 SUBGRADE COMPACTION

* ALL COSTS FOR ITEM SPECIAL - CONCRETE DRIVEWAY SHALL BE INCLUDED IN THE UNIT COST BID (INCLUDING SAWCUT, REMOVAL OF EXISTING PAVEMENT, AND ALL ITEMS SHOWN). ALL REPLACEMENTS TO BE A MINIMUM OF 4' WIDE OR TO THE NEAREST JOINT.

NOTE: 2' WIDE ASPHALT APRON SHALL BE CONSTRUCTED PER THE PAVEMENT BUILDUP SHOWN ON THE ASPHALT DRIVE DETAIL. ALL COSTS FOR THIS WORK SHALL BE INCLUDED AND PAID FOR UNDER ITEM SPECIAL - CONCRETE DRIVEWAY.

File: S:\VEE\3-STANDARDS LIBRARY\JEE STANDARDS\ROAD MAINTENANCE (RM)_DWG\RM-09.DWG - Apr 04, 2013 11:46am - Krock Esser Engineering, Inc.

CONCRETE DRIVE DETAIL

Standard Detail
Vilalge of Boston Heights

KROCK · ESSER

Krock Esser Engineering, Inc.
3030 West Streetsboro Road
Richfield, Ohio 44286
330.657.2145 www.krockesser.com

SHEET:

1 of 1

RM-09